

APPLICATIONS

Household water supply, booster and irrigation systems

FEATURES

- Potable water application
- Can be used with any Grundfos pump
- Five year warranty
- Tank capacity up to 450 litres on request

CONSTRUCTION

- The tanks have a non-toxic butyl rubber diaphragm, dividing the tank chamber in two compartments. The upper compartment contains compressed atmospheric air. The lower compartment has a liner in polypropylene (PP) and is filled with water from the pump
- Vertical installation
- Pre-charge pressure : 150 kPa / 22 psi

Note: the tank pressure must be checked at least twice a year. Set the tank pressure 10% below the pump cut-in pressure.



DIMENSIONS / INSTALLATION

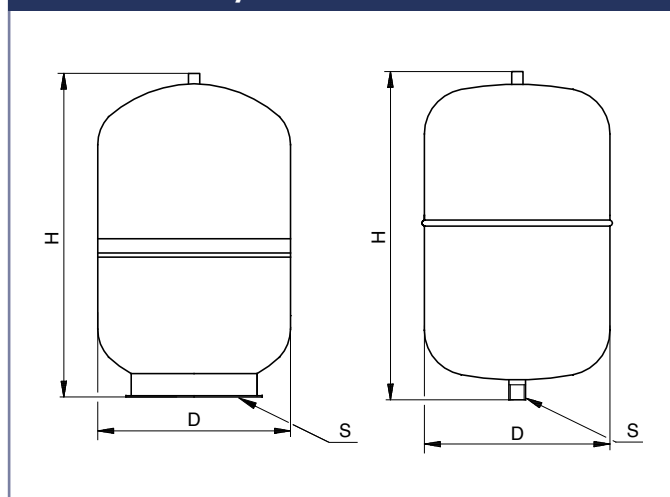

TECHNICAL FEATURES

Tanks	Capacity (litres)	Water temp	Max Operating pressure (kpa/psi)	Mounting type	Connection inlet	Dimensions (mm)		Weight (kg)
						D	H	
PTF8	8	0/90°C	1000/145	Pipe	1”M	202	303	2.3
PTF18	18	0/90°C	1000/145	Pipe	1”M	279	367	4.6
PTF60	60	0/90°C	1000/145	Foot	1”F	397	557	11
PTF80	80	0/90°C	1000/145	Foot	1”F	397	755	16