

APPLICATIONS

The AP35 and AP50 pumps are submersible pumps, specially designed for pumping wastewater and domestic sewage or any other non-aggressive liquid containing solid matter up to 50mm.

They can be used as a fixed or mobile installation, vertically or horizontally (discharge outlet facing up).

- Lifting domestic wastewater from washing machines, toilets etc
- Draining sumps
- Agricultural and industrial transfer of liquids

FEATURES

- Single-phase models supplied with float switch
- Motor cooling provided in all conditions by cooling jacket
- Solid handling capacity: 35mm for AP35 and 50mm for AP50
- Easy service of power cable and float
- Pumped liquid temperature up to 70°C, for limited operating period (2 minutes per 30 minute period)

CONSTRUCTION

- Stainless steel volute, pump housing and impeller
- IP68 moto
- Insulation Class F
- Semi-open vortex impeller
- Silicon carbide mechanical seal (AP35)
- Tungsten carbide mechanical seal (AP50)
- Voltage: 1 x 240V with float switch (A)

TECHNICAL FEATURES

Pumps	Cable (m)	P2 (kW)	1 ph In (A)	Water temp	Outlet	Dimensions		l/min	0	100	200	300	400	500
						A	B							
Unilift AP35-40-06-A1	10	0.6	4	0/55°C	1 1/2" F	376	216	m Head	9.7	7.1	4.4	1.4	-	-
Unilift AP35-40-08-A1	10	0.7	5.5	0/55°C	1 1/2" F	410	216		11.4	9.2	6.6	3.6	-	-
Unilift AP50-50-08-A1	10	0.8	5.9	0/55°C	2" F	436	241		9.1	7.9	6.1	4.0	2.2	-
Unilift AP50-50-11-A1	10	1.1	8	0/55°C	2" F	436	241		11.8	10.2	8.3	6.3	4.2	2.0

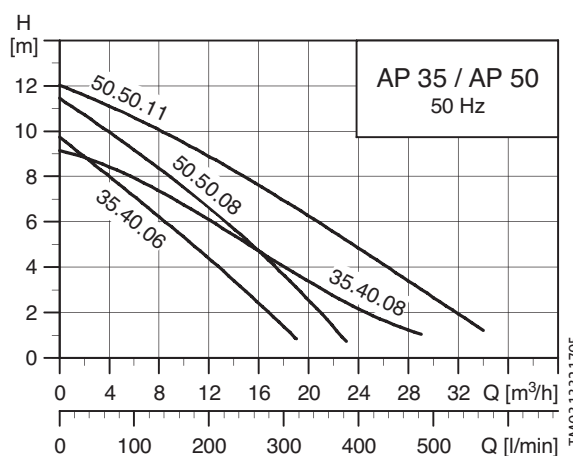

DIMENSIONS / INSTALLATION

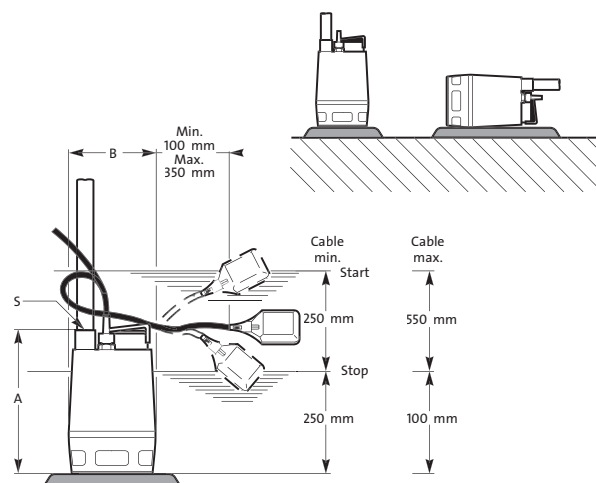

Installation depth: max. 10 m below the water level.