



PC3
Rain Tank Pump Cover



PC3 Protects your pump.



Designed to grace the most livable outdoor settings, the PC3 pump cover from Nylex provides an attractive and practical alternative to protecting your valuable pump from weather, children and the unintentional actions of family pets.

With a slimline moulded base, and ventilated clip-on cover the PC3 can be used to protect tank-to-toilet systems, the pool pump or any other pump application in the garden.

With a depth off the wall of less than 400mm, the PC3 has been designed to fit into narrow side ways along side your home, garage or carport.

Designed and manufactured to meet the toughest conditions, the PC3 is available in a range of contemporary colours to match your existing tank or outdoor setting:



PC3 COVER SPECIFICATIONS

- Dimensions: 400mm wide x 650mm long x 586mm high
- Made from: virgin high-quality, UV-stabilised food-grade polyethylene
- Designed to suit most major brands of domestic pumps, including the Onga WaterSwitch and other systems
- Colours shown above are standard. Other colours are available (subject to longer delivery lead times).
- Will not rust, rot or corrode and never needs painting
- 15 year warranty†

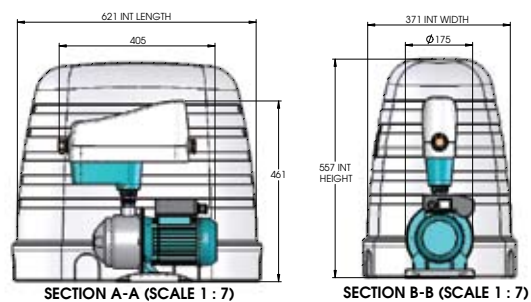
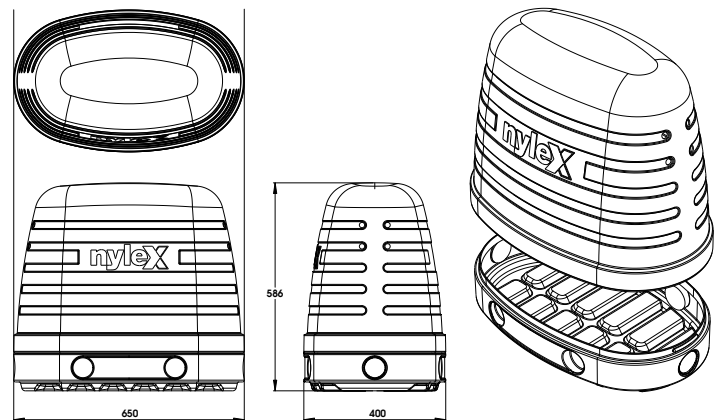

TYPICAL EXAMPLE OF THE PC3 COVER IN USE.

For more information regarding this or any other Nylex product go to nylex.com.au



The information contained in this brochure is given in good faith. The information is accurate at time of printing and may subsequently change without notice. † Subject to our Terms and Conditions.

NYLEX WATER SOLUTIONS PTY LTD (ABN 86 004 758 070)