

GRUNDFOS CM

Horizontal multi-stage pumps up to 7.5 kW

# When customisation, modularity, and reliability are key

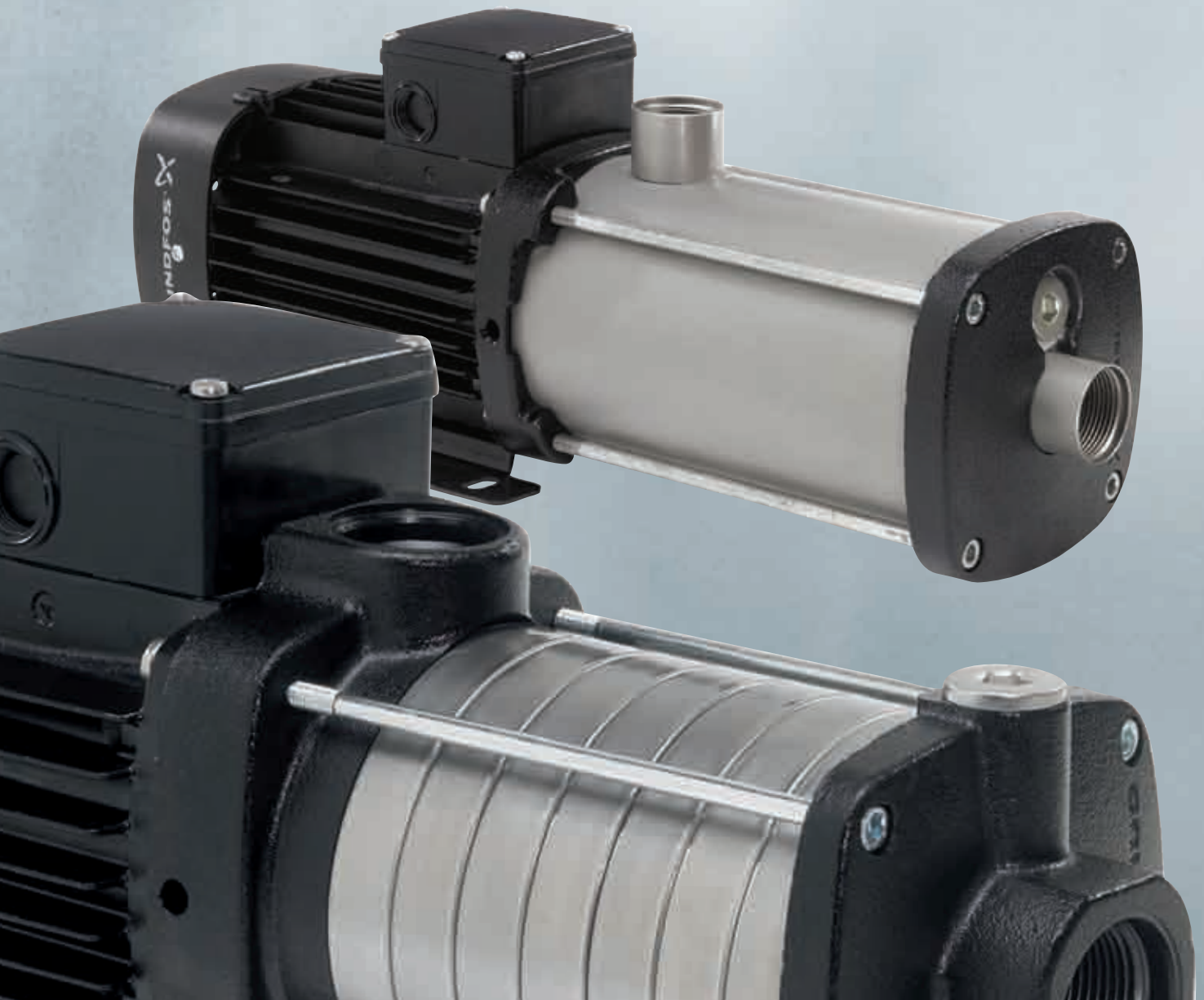

BE > THINK > INNOVATE >

GRUNDFOS 

## A small pump with gigantic potential

It was once said that great things come in small packages. When you meet the Grundfos CM pump for the first time, you'll certainly agree. This horizontal multi-stage pump has been created with compactness and modularity as two of its central features. Add reliability and quiet operation to the mix, and another innovative pump solution from Grundfos is born.

The Grundfos CM is designed to be used in a variety of applications. These include

- Washing & cleaning
- Temperature control
- Water treatment
- Chemical and Pharmaceutical industries
- And more...

Three main models are offered, with a number of variants available thanks to a series of optional components. These main models are constructed in:

- Cast iron (Type A)
- AISI 304/DIN 1.4301 (Type I)
- AISI 316/DIN 1.4401 (Type G)



Chemical and Pharmaceutical Industries



Temperature control

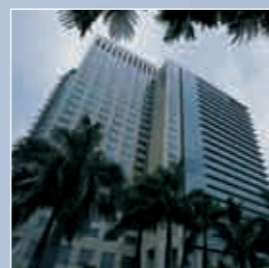

Pressure boosting



Washing and cleaning

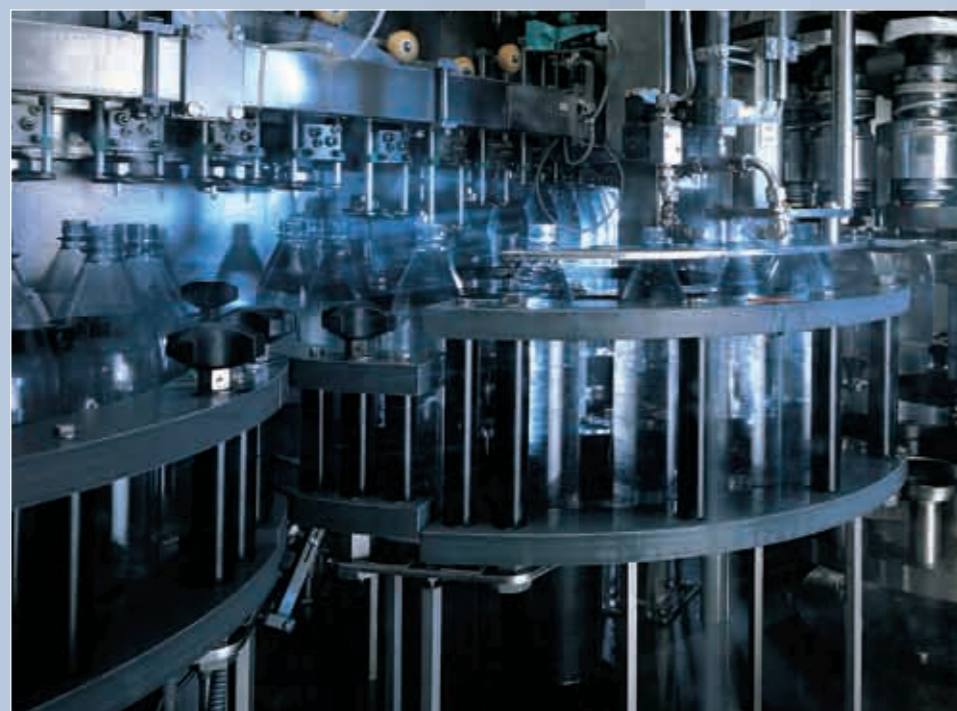

Water treatment

## The CM abbreviation derives from the most basic description of the pump:

Centrifugal Modular. The pump is basically composed of a series of interchangeable modules, all of which have been designed to work together seamlessly, no matter the application.

The CM pump is primarily used as a build-in pump in OEM solutions. Its compactness and flexibility make it an optimal solution for installation and interaction with other components in a larger product. It can also be used as a system pump, connected in complete system solutions, or even as a stand-alone pump.

### Wide temperature range

Thanks to the numerous configuration possibilities and range of materials, the Grundfos CM pump can operate over a wide range of temperatures: from -30 °C to 120 °C. If you require different pumps for different applications, this flexibility and streamlining helps keep maintenance and spare parts costs to a minimum.



CM 3-2-A



CM 1-3-G



CM 5-2-I



CM 3-8-A



CM 5-4-I



CM 10-8-G



CME 3-2-A



CM 3-3-I



CM 5-8-A



CME 1-3-G

# All you've ever wanted, in a size you appreciate

Innovation is at the heart of all Grundfos product solutions. And the Grundfos CM pump is no exception. But innovation sometimes requires more than marching to the beat of your own drum. We've listened to customer feedback and have incorporated this into the product.

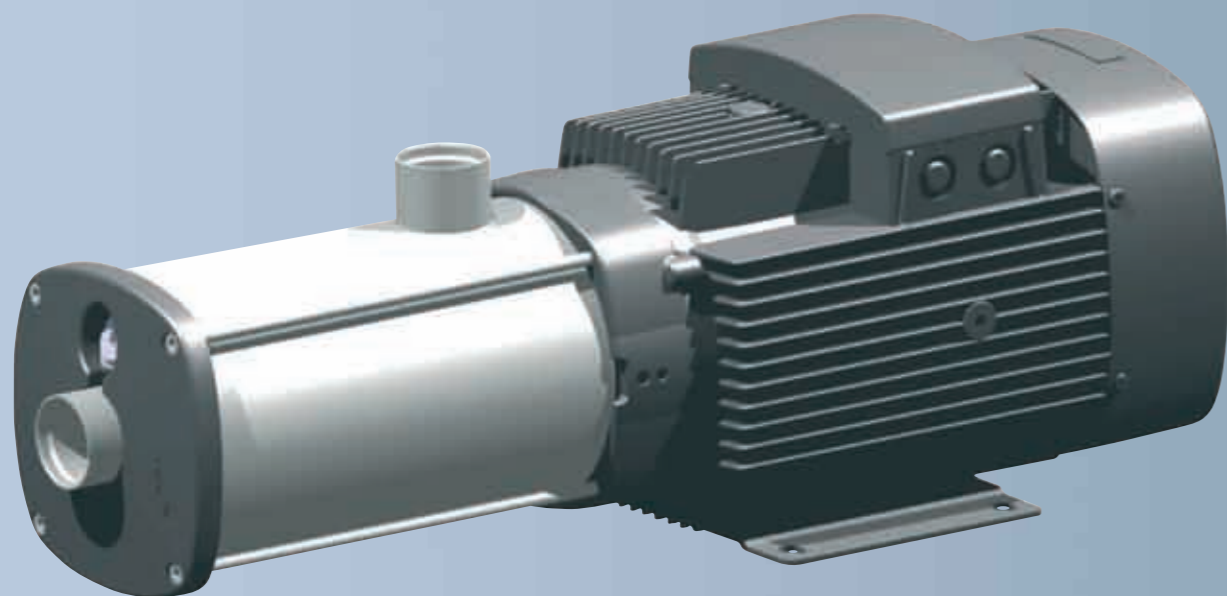

## Compactness

Certain dimensions have been reduced by more than 30% compared to corresponding pumps. And the reduction in size has not triggered a corresponding reduction in performance.

The Grundfos CM5-4 features for example dimensions that take up less physical space compared to the existing Grundfos CHI4-40:

- Width: reduced by over 30%
- Height: reduced by almost 25%
- Length: reduced by almost 10%.

These achievements have only been possible due to use of advanced processes and technologies.

## Reliability

The Grundfos CM has high reliability built-in. For example, clamping of the pump's impellers has been greatly improved by implementing a new stop ring to form a well-defined base. Combining this feature with a NORD-LOCK® washer at the other end of the pump stack creates a robust and reliable design.

What's more, industry-wide problems with sticking of shaft seals where SIC-SIC seal faces are used have been eliminated. The new CM solution builds on both the implementation of a rotation stop on the stationary ring and the presence of different surface finishing on the stationary and the rotating ring.

## Flexibility

While each Grundfos CM pump is individually created, the pump family is designed to be used in a variety of applications. These include

- **Washing & cleaning**
  - Degreasing and washing of production equipment
  - Washing machines
  - Mobile washing units
  - Units for CIP (Cleaning In Place)
- **Temperature control**
  - Electronic data processing
  - Laser equipment
  - Industrial refrigeration
  - Heating and cooling in industrial processes
- **Water treatment**
  - Reverse osmosis
  - Ultra-filtration systems
  - Softening, ionising, demineralising systems
  - Dead end filtration
- **Chemical and Pharmaceutical industries**
  - Distilling systems
  - Dosing / Mixing
  - Evaporation
  - Liquid boosting and transfer

## Flexible range of connections

A flexible range of connections ensures that the customer can utilise the connection systems found in either his or her solution or that of the end-user. This provides an excellent flexibility and simplicity, creating a customised solution without the normal waiting time.

They include:

- Standard thread NPT or Rp
- A combination flange with your choice of flange in DIN, JIS and ANSI standards
- A PJE connection, which is especially good for high-pressure applications
- A Tri-clamp solution.



## Materials

Different materials are better suited for different applications. The modular concept of the Grundfos CM pump allows you to select the material that best suits your needs.

### Cast iron

Solid & reliable, it is perfect for washing and cleaning, pressure boosting, and chillers.

### AISI 304/DIN 1.4301 stainless steel

AISI304 stainless steel is the perfect choice for water and non-corrosive liquids used in water treatment, temperature control, pressure boosting, and washing & cleaning.

### AISI 316/DIN 1.4401 stainless steel

AISI 316 stainless steel offers a high degree of corrosion protection against aggressive liquids used in chemical, pharmaceutical, food & beverage and water treatment applications.

### Quiet operation

CM pumps are often used in small spaces, where loud operation is undesirable. Aside from sounding better, quiet operation eliminates the need for extra insulation around the product.

# The details make the difference

From end to end, Grundfos' well-known quality and attention to detail makes the difference between Grundfos CM and competitive pumps.

**Power**  
0.25 - 7.5 kW  
0.3 Hp - 10 Hp

**Flow**  
50Hz  
1m<sup>3</sup>/h - 25m<sup>3</sup>/h  
  
60Hz  
1m<sup>3</sup>/h - 30m<sup>3</sup>/h  
4.4gpm - 132gpm

**Temp**  
-30 °C - +120 °C  
-22 °F - +248 °F

**Pressure**  
Head 12 bar / 174 PSI  
System pressure 16 bar / 232 PSI



#### The broad motor programme

is available for global usage. It contains both single- and three-phase motors, including E-versions and wall mounted VFD solution. Grundfos motors are or can be directly protected by Klixon, PTC and PT100 or by the frequency drive itself. The motor is IP55 as standard, and for kondensing enviroments we supply you with a tropicalised variant.  
Remember: We can meet all your motor needs!



#### Installation indicator

A standard feature on all three-phase CM pumps. It shows whether the motor has been connected properly.  
Remember: Your installation runs better when the pump rotates in the right direction.

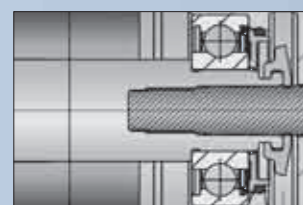

#### A double protection device

for our motor bearings is in place to keep maintenance to a minimum.  
Remember: You can rely on Grundfos for top performance, even within harsh environments.

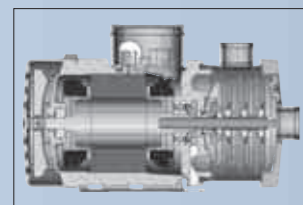

#### Our goal of compact and easy handling

comes to life in the new CM pump's design.  
Remember: Compactness allows the CM pump to fit in everywhere.

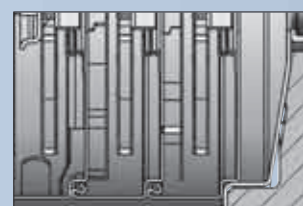

#### Stainless steel hydraulics

across the entire range provides the highest performance in the long term. Pump variants are available in AISI 304/ DIN 1.4301 and AISI 316/DIN 1.4401 stainless steel.

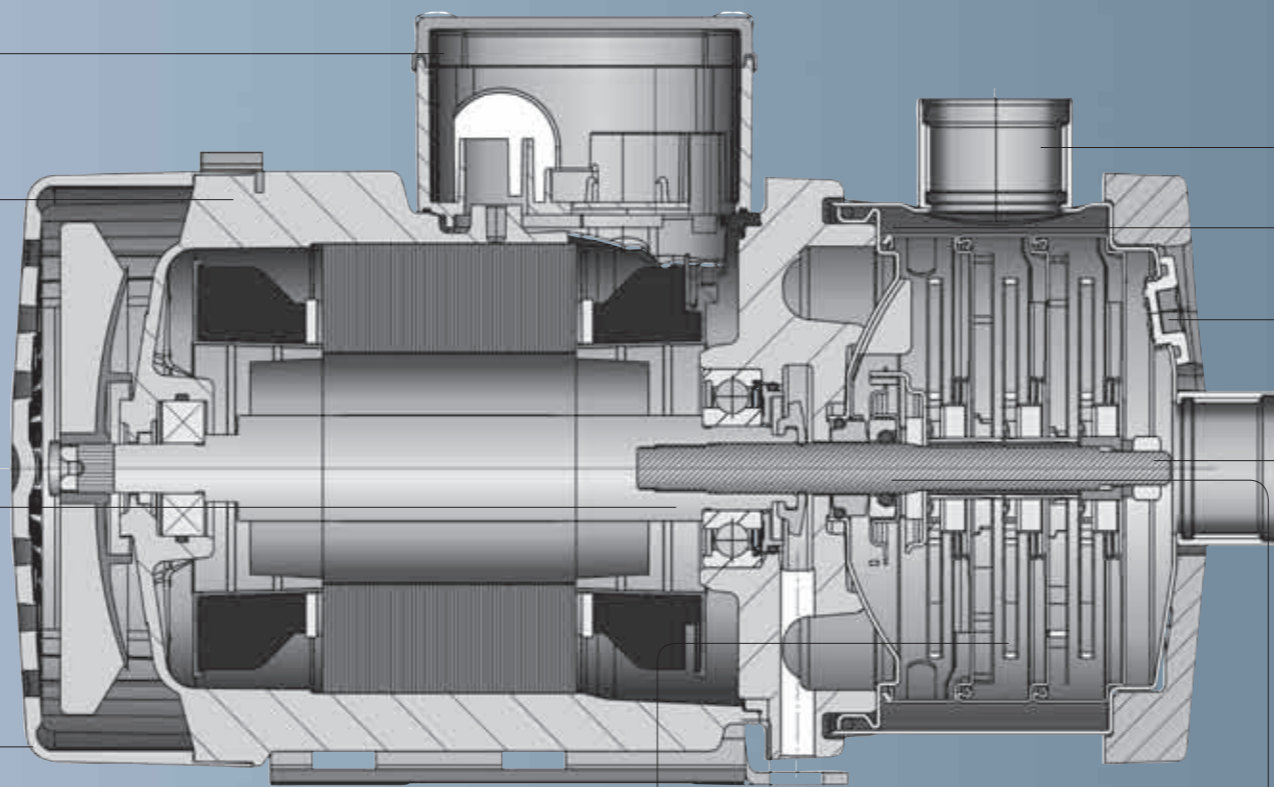

**The suction and discharge ports** are designed to withstand corrosive liquids. NPT and RP threading are standard. This allows a wide range of threaded flange and clamp adapters to be used with ease. Remember prepared for O-ring: However you prefer to put things together, Grundfos makes it easy.



**Our sleeve O-ring** assembly device features a safe and simple design for temperatures from -30 to +120 °C. Remember: Grundfos CM can handle applications from chilling to heating.

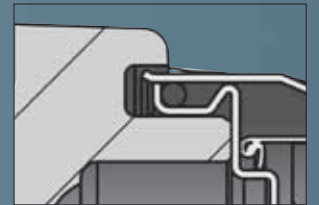

**The Grundfos filling and draining plug** in stainless steel is sealed by an o-ring. Remember: Leakage is eliminated effortlessly.



**A highly reliable combination of joint elements** keeps the pump in shape, and makes assembly and disassembly possible from the pump side only. Remember: Scheduled service takes place easy and fast.

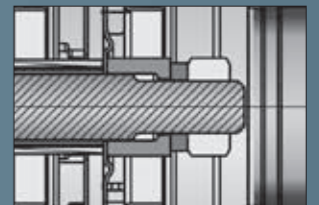



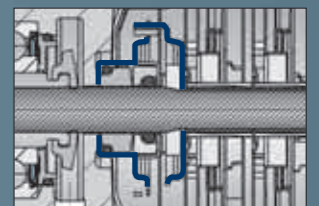

**A unique o-ring shaft seal** is designed to provide excellent dry running, non-sticking capabilities. Remember: Under tough conditions, Grundfos CM provides extra high reliability.





## Accessories

	Description
	<p><b>Adapter for JIS</b> Flexible adapter according to all three standards (DIN, JIS, ANSI).</p>
	<p><b>Adapter for Tri-clamp</b> Tri-clamp connection is of hygienic design with a sanitary coupling for use in the pharmaceutical and food and beverage industry. The connection is in accordance with EN/DIN 32676.</p>
	<p><b>Adapter for VICTAULIC</b> PJE couplings are designed for use in a wide range of industrial applications.</p>
	<p><b>Remote control, R100</b> (product number: 625333) Used for wireless communication with the CME pump. Communication takes place via IR.</p>
	<p><b>Potentiometer for CME</b> (product number: 625468) Used for set-point setting and start/stop of the CME pump.</p>
	<p><b>CIU communication interface unit for CME</b> The CIU units enable communication of operating data, such as measured values and setpoints, between CME pumps and a building management system. The CIU unit incorporates a 24-240 VAC/VDC power supply module and a CIM module. It can either be mounted on a DIN rail or on a wall.</p>



CM pumps are always part of a bigger picture. Grundfos offers a full range of accessories to support the CM range. Here are a few selected examples – the complete range can be found on WebCAPS.

# ALL THE INFORMATION YOU NEED IS ONLINE

Grundfos WebCAPS is an online product selection tool, but it offers much more than that. The site compiles all the product-related information you could ever need.

### What you can find in WebCAPS

**Catalogue** – includes all products available in your region, complete with technical information, drawings, descriptions, performance curves, etc.

**Literature** – find everything from data booklets through installation & operating instructions to product brochures.

**Service** – the place to find service instructions (including video tutorials), service parts lists, assembly drawings, etc.

**Sizing** – enter your system requirements for instant recommendations. Includes Life Cycle Cost calculations.

**Replacement** – enter the make and model of your old pump for an instant replacement recommendation.

**CAD drawings** – download DXF and DWG files as required.

For offline use, WinCAPS is a CD-ROM version of WebCAPS. Contact Grundfos to order.



## THE GRUNDFOS CM PUMP

When customisation, modularity, and reliability are key, turn to the new Grundfos CM pump. This horizontal multistage pump is a compact, modular, reliable and quiet pump solution from Grundfos.

The Grundfos CM is designed to be used in a variety of applications including

- Washing & cleaning
- Temperature control
- Water treatment
- Chemical and Pharmaceutical industries
- And more...

Three main models are offered, with a number of variants available through optional components. These main models are constructed in:

- Cast iron ASTM A48: Class 30B/EN-JL 1030
- AISI304/DIN 1.4301 Stainless Steel
- AISI316/DIN 1.4401 Stainless Steel.

### GRUNDFOS Management A/S

Poul Due Jensens Vej 7  
DK-8850 Bjerringbro  
Tel: +45 87 50 14 00

[www.grundfos.com](http://www.grundfos.com)

The name Grundfos, the Grundfos logo, and the payoff Be—Think—Innovate are registered trademarks owned by Grundfos Management A/S or Grundfos A/S, Denmark. All rights reserved worldwide.