

EVERTRENCH POLYMER TRENCH LINER

Evertrench™

*The trench system with
more holes for
superior performance.*

*Exceeds
Australian standard
requirements of
total area of transfer
holes per metre.*

*Meets
regulatory authority
requirements for
use throughout
Australia.*

*Suitable for
virtually any site and
layout combination.*

*Accepts
all forms of
treated domestic
waste-water,
where local
authority permits.*

*Fast and easy
to install.*

*Strong, durable
corrugated design
and injection
moulded polymer
construction.*

*Available in three
sizes to suit most
applications.*

*Suitable for
below-ground
storm-water
disposal and
soakage trench
systems.*



Evertrench Polymer Trench Liner has a lot of holes. In fact, more holes than required by the Australian Standard. We find it works much better that way. And along with Evertrench's easy installation, efficiency and durability, you'll find it works best for you, too.

EI EVERHARD
INDUSTRIES
Everlasting Quality

Easy installation. Efficient operation

Evertrench Polymer Trench Liner is widely regarded as one of the best systems now available for the disposal of waste-water in unsewered areas. With Evertrench, family health is protected by providing safe and efficient disposal of waste-water from kitchen sink, bathroom and shower, laundry tubs and septic system.

Easy to handle and install.

Evertrench is injection moulded high quality polymer in lightweight lengths of 1.5 metres, enabling easy installation by one person. The corrugated design means sections can be easily interlocked using no extra parts or tools.

Evertrench is suitable for virtually every site and layout combination. Trenches must be designed to meet the needs of the waste-water system and to suit the condition of the soil. Evertrench is available in three standard sizes to match most requirements.

Follow the step by step instructions (on the back of this brochure) and you'll find installing Evertrench is simple, speedy and safe.*

**Check State or local regulations for specific requirements.*



Accessories for optimum performance.

Evertrench is designed for use with proven Geotextile fabric. This woven plastic cloth allows liquid to pass through the trench, whilst preventing the ingress of soil from the outside. Highly durable, Geotextile will not rot or deteriorate over time.

Genuine Everhard Spreader Bars are an integral part of the Evertrench system, adding strength to the trench whilst being lightweight and easy to handle. When correctly installed, they will prevent the trench collapsing, buckling or bowing.

Geotextile, Everhard Trench Liner Spreader Bars and End Caps are readily available to suit every installation.

Superior operational efficiency.

Unlike traditional trenches, which are filled with rubble or crushed rock, Evertrench provides 100% uncluttered temporary waste-water collection and storage.

The entire arched interior space of Evertrench is available to hold fluid and then dispose of it through the trench floor area and through the punched holes in the side walls.

Evertrench also out-performs slotted pipe by allowing quicker dispersion of fluid to surrounding aggregate and soil for transpiration or evaporation, with less risk of blockage.

Totally efficient, free-flowing waste-water disposal, it's hard to go past Evertrench.



on. Everhard durability.

Strong and durable.

Evertrench Polymer Trench Liner, correctly installed, is capable of supporting loads of 400kg over each metre of length. The continuous corrugated design offers excellent structural strength, while the injection moulded polymer is extremely resilient and tough. It is also sufficiently U.V. stabilised for protection whilst in storage. Installed correctly, Evertrench will provide many years of safe, efficient, trouble-free operation.

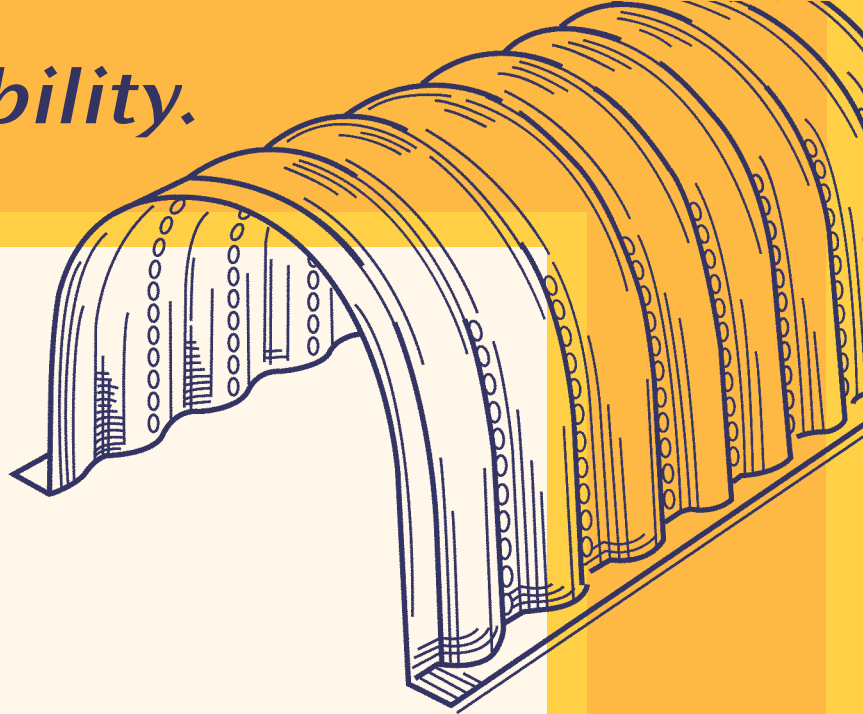

SIZES AND CAPACITIES

EVERTRENCH TYPE	OVERALL DEPTH	LENGTH OF UNIT	OVERALL EXT. WIDTH AT BASE	AVERAGE INTERNAL WIDTH	STORAGE CAPACITY PER LINEAL METRE	WEIGHT OF UNIT
	mm	mm	mm	mm	litres	kg
230 SMALL	230	1500	500	460	70	2.75
350 LARGE	350	1500	500	460	140	3.5
410 JUMBO	410	1500	500	460	175	4.5

GEOTEXTILE A12 WIDTHS: 600mm, 800mm, 1000mm, 1200mm, 2000mm.

Dimensions may be subject to minor variations during postmoulding cooling and/or transport. Plastic End Caps and Spreader Bar Braces available to suit all three Evertrench sizes.

Everhard's Complete Septic System.

Everhard manufactures and supplies a complete range of septic system components:

- Grease Traps • Septic Tanks • Xtratreat Filters
- Pump Wells • Distribution Boxes
- Trench Liner, Spreader Bars and End Caps • Geotextile

Where septic systems are not practical, the Everhard Aqua-nova Aerated Waste-water Treatment System offers safe re-use of waste-water.

Everhard recommends
"BIDIM" A12 Geotextile Fabric
or equivalent.

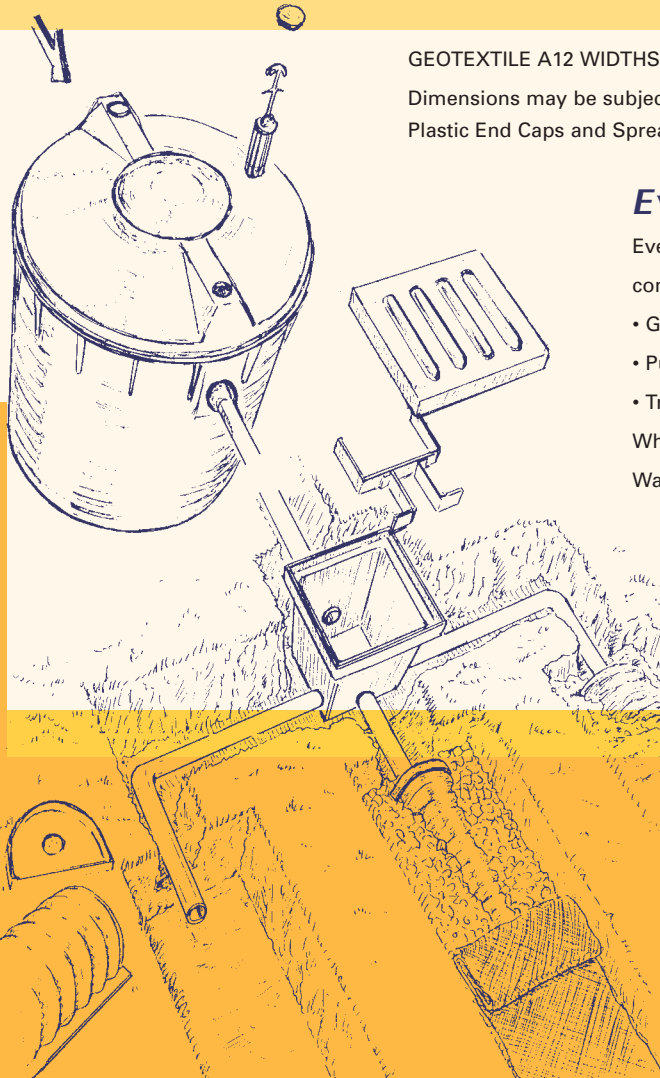

Step by step installation instructions.

Everhard Industries recommends the following installation procedures for its range of Evertrench Polymer Trench Liners. These have been found to be generally adequate for many normal domestic applications. Local conditions will affect the method of waste-water disposal, the size of the trench or bed, and the type of Trench Liner to be selected.

It should be noted that all layouts for waste-water disposal land application areas must be designed by competent and authorised persons, taking the following factors into account:

- The volume of waste-water, based on household size and appliances.
- The absorption capability of the surrounding soil.
- Limitations imposed by site conditions, such as slope, contours, etc.

Before beginning design and construction of the waste-water disposal system, check with State and local authorities for particular requirements for your area.

METHOD 1: Absorption Trench These are generally limited to sites where soil is considered permeable enough to "soak up" the projected amounts of waste-water. A trench should be wide enough to accept the selected Evertrench Liner and deep enough so that the top of the selected Liner is not less than 100mm below the soil surface level.

1. Excavate the trench along a level site contour to provide at least 100mm cover over the top of the Liner.
2. The trench floor should be level, evenly raked, and have no low spots which would allow "ponding".
3. Allow at least 75mm overlap for each length of Evertrench.
4. Fit three Spreader Bars into each standard Evertrench Liner, the first 220mm from the inlet end, then equally spaced along the excavation.
5. Cut the pipe entry hole in one Trench Liner End Cap and fit the Caps to the Liner. Connect piping from the septic tank or sullage distributor.
6. Place a quantity of 20-25mm aggregate material along the Trench Liner and at both ends, so that the top of the Liner is just covered. Rake level.
7. Lay Geotextile Fabric over the aggregate for the full length of the trench.
8. Cover the Geotextile with a layer of approved sandy loam and leave a mound for natural compaction. Turf may be laid over the trench area. **DO NOT COMPACT** the trench area or expose it to traffic.

METHOD 2: Transpiration Trenches and Beds These are generally used where local soil conditions cannot cope with the volume of waste-water in normal narrow absorption trench systems. Transpiration encourages treated waste-water to be taken up by plant roots over a wide area, as well as permeating the soil, offering additional safety for soil absorption systems. Beds consist of standard width trenches, deeper than normal, with the area above the selected Trench Liner of much greater width, and filled with aggregate allowing easier movement of moisture.

1. Excavate an area 1800mm wide, 300mm deep along a level site contour.
2. Excavate a central trench along the full length of the prepared area, to take a selected Liner. The top should be level with the bottom of the prepared area. The floor should be level, evenly raked, with no low spots.
3. Carry out Steps 3, 4, 5, 6 & 7 listed for Method 1 (Absorption Trench).
8. Cover the Geotextile and floor of the wider excavation with 100mm of 10mm aggregate, then 100mm of coarse sand, and finally with sandy loam.
9. Leave a mound for natural compaction. Turf may be laid over the area. **DO NOT COMPACT** the area or expose it to traffic.

Everhard recommends "BIDIM" A12 Geotextile Fabric or equivalent.

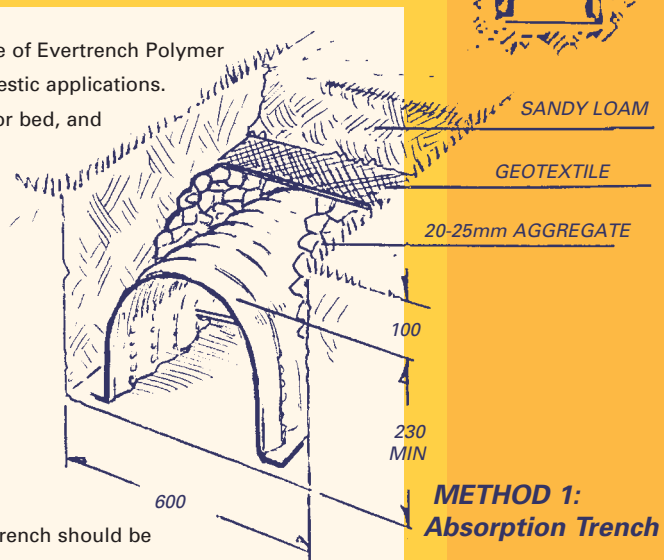

**METHOD 1:
Absorption Trench**

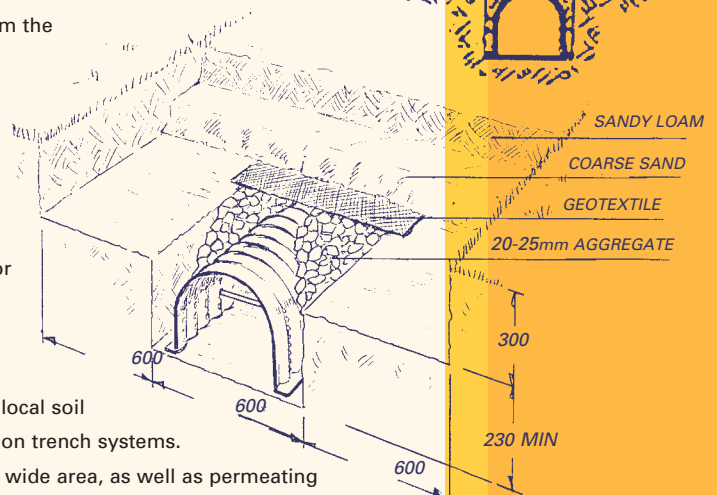

**METHOD 2:
Transpiration
Trenches and Beds**

QUEENSLAND
Geebung, Brisbane -
Tel: (07) 3265 3999
Fax: (07) 3265 2111
Slacks Creek,
Brisbane -
Tel: (07) 3208 7022
Fax: (07) 3808 0000
Sunshine Coast -
Tel: (07) 5445 1688
Fax: (07) 5445 1605
Gold Coast -
Tel: (07) 5539 3599
Fax: (07) 5597 1678

Townsville -
Tel: (07) 4779 0222
Fax: (07) 4725 1147
Cairns -
Tel: (07) 4031 3558
Fax: (07) 4031 6034

NEW SOUTH WALES
Smithfield, Sydney -
Tel: (02) 9757 2799
Fax: (02) 9757 2446
Port Macquarie -
Tel: (02) 6581 3833
Fax: (02) 6581 3320

VICTORIA
Braeside, Melbourne -
Tel: (03) 9586 7344
Fax: (03) 9586 7341

SOUTH AUSTRALIA
Adelaide -
Tel: (08) 8212 1700
Fax: (08) 8231 1643

WESTERN AUSTRALIA
Perth -
Tel: (08) 9328 6644
Fax: (08) 9227 9259

TASMANIA
Hobart -
Tel: (03) 6273 3455
Fax: (03) 6273 1901

A.C.T.
Canberra -
Tel: (02) 6280 4177
Fax: (02) 6280 7660

NEW ZEALAND
Auckland -
Tel: (64-9) 267 0160
Fax: (64-9) 267 2762

HEAD OFFICE:

405 Newman Rd Geebung Qld 4034
Tel: (07) 3265 3999 Fax: (07) 3265 2111
E-mail: everhard@everhard.com.au
Internet: www.everhard.com.au

